

Instruction Manual

for installing
Preloaded (HSFG) Bolting
with

TurnaSure[®]
DIRECT TENSION INDICATORS
CE Marked EN 14399-9

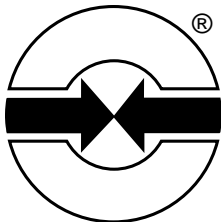

TurnaSure LLC

TABLE OF CONTENTS

Introduction	1
Theory of Preloaded Bolting Assemblies	2
Tightening of Preloaded Assemblies.....	3
Recommended DTI Assembly Installation Procedure	4
Configuration of DTI Preloaded Assemblies	6
Inspection of Assembled DTIs	11
Lubrication.....	14



TurnaSure LLC (July 2011 edition)

International Headquarters
340 E. Maple Avenue, Suite 206
Langhorne, PA 19047 U.S.A.

Phone: 215-750-1300
Fax: 215-750-6300
Website: www.turnasure.com

INTRODUCTION

Preloaded Bolting assemblies otherwise known as 'High Strength Friction Grip Bolting' are well established as an economical and efficient method of providing connections in structural steelwork.

The rules for the use of Preloaded Bolting assemblies in steel structures within Europe are defined in the recently developed European Standards EN 1090-2 and EN 1993 (Eurocode 3).

Preloaded Bolting assemblies are tightened to produce a preload in the bolt which generates frictional resistance to movement between the plies of the connection. These assemblies can be used in any type of structural steelwork joint, but more especially where the following factors apply:

1. Fatigue
2. Vibration
3. Load Reversal
4. Dimensional Stability

The basic requirement of the Preloaded Bolting assembly is that a correct and reproducible preload in the bolt is achieved.

Direct Tension Indicator (DTI) assemblies, a form of Preloaded Bolting assembly, are one of several such methods of ensuring that the preload is consistently achieved. Among the many advantages of the system is the repeatable bolt preload that can be achieved regardless of the lubrication that has been applied to the bolting assembly.

This booklet is written for Engineers, Supervisors, Inspectors and Erection Staff, to assist them in the correct installation of DTI assemblies.

TurnaSure LLC has many years of experience in the supply of DTIs for use in structural steelwork, both in the UK, USA and EU, and can provide a range of technical support including technical reports and information on fastener specifications.

THEORY OF PRELOADED BOLTING ASSEMBLIES

The principle of Preloaded bolted connections relies upon tensioning each bolt in the connection to a specified minimum preload so that the required clamping force will be induced at the connection interface. Shear loads are then transferred by frictional resistance at the joint interface rather than by bearing on the bolt shanks and hole faces. In this type of connection there will be no movement of the connected materials when the connection is subjected to these loads.

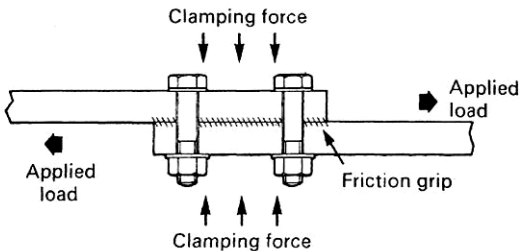

When axial tensile loads are applied to the bolt through the bolted connection, preloading of the connection to a specified minimum is also important, particularly if the loads are cyclical and could induce loosening or fatigue failure of the bolts. The clamping force developed at the specified minimum bolt preload should be greater than the applied loads. This will prevent the plies from separating or the bolts from developing any significant increase in axial tensile stress over the installed preload stress.

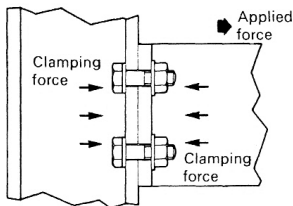

TIGHTENING OF PRELOADED ASSEMBLIES

The essential requirement for preloaded connections is that the individual bolts are correctly tightened to the specified minimum preload; EN 1993.1.8 (Eurocode 3) specifies that to develop the necessary clamp force in the connection each bolt must be preloaded to 70% of the nominal bolt tensile strength.

The permitted methods of preloading in EN 1090-2 are dependent on either movement of the nut along the bolt thread by a specified amount or the application of a calculated value of torque (turning moment) to the nut.

Methods that depend on displacement of the nut:

1. The DTI method depends on the deformation of protrusions that have been extruded from the face of a washer. The DTI is calibrated so that when a specified average gap is reached the required preload is achieved.
2. The Highways Agency part-turn method requires each bolt to be tightened by torque to bring the steelwork into contact (each bolt diameter uses a different torque value). A part-turn, a minimum of a half turn, is then applied to develop the required preload.

Methods that depend on the application of torque:

1. The Combined method requires the bolt to be torqued to 75% of the required preload; the required torque is calculated from data obtained from the EN 14399-2 – Fitness for Purpose test. A small part-turn, less than one third turn, is then applied to develop the required preload.
2. The Torque Control method again uses a value of torque calculated from data obtained from the EN 14399-2 – Fitness for Purpose test.
3. The bolts with the HRC method (TC bolts) are tightened using a special wrench where the nut is rotated while reacting against the splined bolt end. The HRC bolts are calibrated so that when the nut stops rotating the spline shears at a breakneck and the required preload is achieved.

Methods that depend on displacement of the nut only require lubrication to rotate the nut to achieve the preload; those dependent on torque control require close control of the lubrication and storage on site. The required lubrication is specified by K – class in EN 1090-2 and EN 14399-2. For details of the K- classes and their specified use see page (14).

RECOMMENDED DTI ASSEMBLY INSTALLATION PROCEDURE

Step 1

Bring the steel sections to be joined together and align the holes with drift pins. **Bolts should not be used as drift pins to achieve alignment; this could result in thread damage that prevents the DTI Assembly working correctly.**

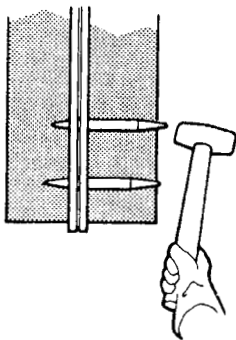

Step 2

Fill the remaining the holes with DTI Assemblies of the correct size. Partially tension the assemblies to snug the connection, this is achieved when the steel sections are in contact and the protrusions of the DTIs are just starting to be deformed. At this point there will be approximately 50% of the minimum specified bolt preload applied.

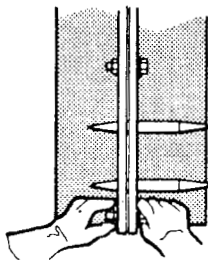

DTI Assemblies can be partially tensioned by:

1. Using a standard air or electric wrench.
2. Using a manual spanner or torque wrench.

When tightening a pattern of assemblies work from the most rigid part of the connection to the free edges.

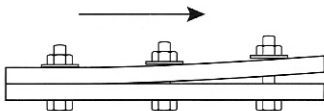

Step 3

Tension the assemblies until the DTIs are flattened to the specified average gap. Again, work from the most rigid part of the connection towards the free edges. Leave the drift pins in during this stage of the process. Premature removal of the drift pins may cause trapping of the assemblies by joint slippage.

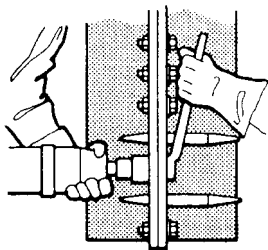

This is especially critical with DTI Assemblies where the DTI is fitted under the nut and tightened by the nut. If the bolt is trapped by the plies of the connection the correct tension may not be generated in the bolt.

Step 4

Knock out the remaining drift pins and replace them with DTI assemblies and tighten to the specified gap.

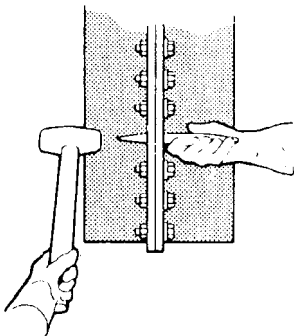

Systematic Tightening

Connections should be snugged and tensioned in a systematic manner. A pattern for snugging the connection is chosen that draws the component parts together without any excessive bending. The initial tightening should start at the most rigid part of the connection. With a single or double row of assemblies, where the steel is in contact, working toward the end where there is no contact. In an assembly pattern, such as a large web splice plate in a girder, start at the centre and work out toward the free edges of the plate. The same pattern should be used when the assemblies are finally tensioned.

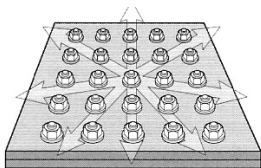

CONFIGURATION OF DTI PRELOADED ASSEMBLIES

DTIs can be assembled under either the bolt head or nut; similarly the assemblies can be tightened by rotation of either the nut or bolt head; this depends on access for the tightening wrench. Because tightening of a DTI assembly is not dependent on torque or the amount of lubrication applied, there are no restrictions on the method of assembly used with DTIs.

The following four diagrams show the configuration of DTI assemblies that are specified in the latest amendment of EN 1090-2.

A specific requirement of EN 1090-2 is that when assemblies of 10.9 preloaded bolts are used, harden washers (EN 14399 – 5 or – 6) must be used under both the bolt head and nut. With assemblies of 8.8 preloaded bolts hardened washers are only required under the turned element of the assembly.

Similarly EN 1090-2 requires that 'plate washers' must be used where the steelwork has oversize clearance holes and both short and long slotted holes.

When assembled as shown in figure 2 and tightened with the latest lightweight electric wrenches; there are significant advantages that include ease of installation, a relatively quiet and vibration free operation, that can be carried out by a single operator.

TIGHTENING OF THE ASSEMBLY BY ROTATION OF THE NUT

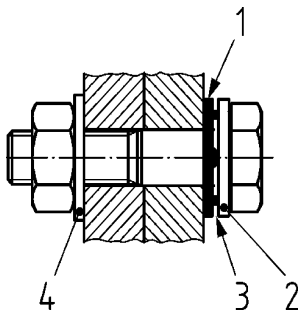

Figure 1 - Under Bolt Head Fitting

Key

- 1 – Direct tension indicator
- 2 – Bolt face washer (not required for property class 8.8)
- 3 – Gap
- 4 – Washer according to EN 14339-5 or-6

Note: Independent Studies by approved laboratories have shown that with the unique TurnaSure geometry the “Bolt Face” and “Nut Face” washers shown here result in a slightly wider standard deviation in assembly loads that when these washers are dispensed with altogether. TurnaSure recommends simply placing the nut directly on top of the DTI protrusions for these assemblies. Until EN 1090-2 allows these extra washers to be an option, they have to be used, unless the Project Specification permits tensioning of the assemblies without them.

TIGHTENING OF THE ASSEMBLY BY ROTATION OF THE NUT

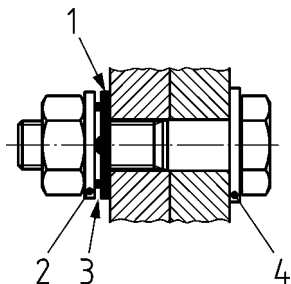

Figure 2 - Under Nut Fitting

Key

- 1 – Direct tension indicator
- 2 – Nut face washer
- 3 – Gap
- 4 – Washer according to EN 14399-6 (not required for property class 8.8)

Note: Independent Studies by approved laboratories have shown that with the unique TurnaSure geometry the “Bolt Face” and “Nut Face” washers shown here result in a slightly wider standard deviation in assembly loads that when these washers are dispensed with altogether. TurnaSure recommends simply placing the nut directly on top of the DTI protrusions for these assemblies. Until EN 1090-2 allows these extra washers to be an option, they have to be used, unless the Project Specification permits tensioning of the assemblies without them.

TIGHTENING OF THE ASSEMBLY BY ROTATION OF THE BOLT HEAD

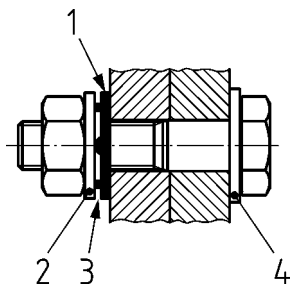

Figure 3 - Under Nut Fitting

Key

- 1 – Direct tension indicator
- 2 – Nut face washer
- 3 – Gap
- 4 – Washer according to EN 14399-6

Note: Independent Studies by approved laboratories have shown that with the unique TurnaSure geometry the “Bolt Face” and “Nut Face” washers shown here result in a slightly wider standard deviation in assembly loads that when these washers are dispensed with altogether. TurnaSure recommends simply placing the nut directly on top of the DTI protrusions for these assemblies. Until EN 1090-2 allows these extra washers to be an option, they have to be used, unless the Project Specification permits tensioning of the assemblies without them.

TIGHTENING OF THE ASSEMBLY BY ROTATION OF THE BOLT HEAD

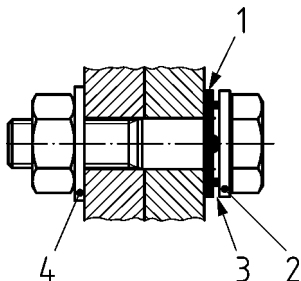

Figure 4 - Under Bolt Head Fitting

Key

- 1 – Direct tension indicator
- 2 – Bolt face washer (not required for property class 8.8)
- 3 – Gap
- 4 – Washer according to EN 14339-5 or-6 (not required for property Class 8.8)

Note: Independent Studies by approved laboratories have shown that with the unique TurnaSure geometry the “Bolt Face” and “Nut Face” washers shown here result in a slightly wider standard deviation in assembly loads that when these washers are dispensed with altogether. TurnaSure recommends simply placing the nut directly on top of the DTI protrusions for these assemblies. Until EN 1090-2 allows these extra washers to be an option, they have to be used, unless the Project Specification permits tensioning of the assemblies without them.

INSPECTION OF ASSEMBLED DTIs

DTIs are checked for correct assembly and tightening with the specified feeler gauge in the space between the protusions, see figure 5.

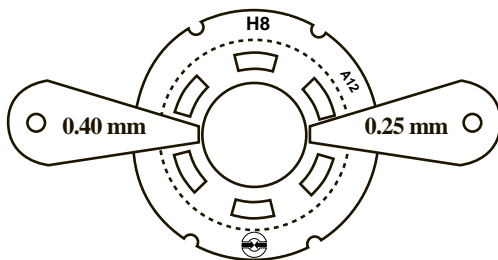

Figure 5

The feeler gauge required is specified in table 1 for all configurations of DTI assemblies, bolt property class and coating.

Table 1 – Thickness of the feeler gauge

Direct tension indicator positions	Designation H8 and H10 Thickness of feeler gauge
Under bolt head, when nut is rotated (Figure 1)	0.40 mm
Under nut, when bolt is rotated (Figure 3)	
Under nut, when nut is rotated (Figure 2)	0.25 mm
Under bolt head, when bolt is rotated (Figure 4)	

Due to variations in steelwork components it is unusual for DTI assemblies to flatten the protusions of the DTI evenly, see figure 6.

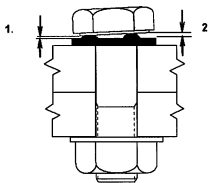

Figure 4 - Under Bolt Head Fitting

Key

1. 'No go' gap if refusal occurs.
2. 'Go' gap if refusal does not occur.

To standardise the method of checking that the assembly is correctly tightened EN 1090-2 Annex J specifies the number of gaps for each type of DTI that the feeler gauge must not enter, see table 2.

Table 2 – Feeler gauge refusals

Number of direct tension indicator protusions	Minimum number of feeler gauge refusals
4	3
5	3
6	4
7	4
8	5
9	5

Annex J of EN 1090-2 includes a requirement that no more than 10% of the direct tension indicators in a connection bolt group shall exhibit full compression of the indicators. This is due to be considered for change at the next revision of EN 1090-2.

Within the United Kingdom the following clause has been included in the National Structural Steelwork Specification for Building Construction – 5th Edition – CE Marking Version.

6.3.3 INSPECTION DURING AND AFTER TIGHTENING

Unless otherwise stated in the Project Specification, inspection shall comply with the requirements specified in BS EN 1090-2 for Execution Class 2. Unless prohibited by the Project Specification, the tightening of direct tension indicators to apparent full compression in more than 10% of cases shall not be a cause for rejection provided that the manufacturer's certificate of conformity confirms that is acceptable in terms of the specified suitability tests.

For TurnaSure® direct tension indicators the report from Rowan University in the USA on “Load – rotation tests of M24 x 90 HR 10.9 Galvanized Structural Bolt Assemblies with DTIs”, dated 29th October 2010 is considered to meet this requirement; copies of the report are available from TurnaSure LLC.

ON SITE TESTING

If required by the Project Specification on site testing of DTI assemblies shall be carried out in accordance with Annex H of EN 1090-2. Eight sample assemblies are to be taken for each bolt diameter, fitted in a load cell and tightened to the specified gap.

The DTI assemblies shall meet the preload ($F_{p,C}$) values as specified in the following – $F_{p,C} \leq F_{b,l} \leq 1.2F_{p,C}$ and table 3.

Table 3 – Preload Values in kN

Property Class	Bolt diameter in mm							
	12	16	20	22	24	27	30	36
8.8	47	88	137	170	198	257	314	458
10.9	59	110	172	212	247	321	393	572

LUBRICATION

Lubrication is one of most critical features of a preloaded bolting assembly; DTI assemblies require sufficient lubrication to achieve the minimum preload and the further rotation of $\Delta\theta_2$. Other systems such as 'torque control' need significantly more control; EN 1090-2 and EN 14399-2 specify by means of a K- class the requirements for each tightening method.

K0 – no specific requirements except to achieve preload and $\Delta\theta_2$.

K1 – individual values of the k -factor shall be in the range $0.10 \leq k_i \leq 0.16$.

K2 – mean values of the k -factor shall be in the range $0.10 \leq k_m \leq 0.23$ and the coefficient of variation $V_k \leq 0.10$.

The k -factor is determined as part of the suitability for preloading test in EN 14399-2.

The following table details the K-class required for each tightening method.

Tightening Method	K-class Required
DTI Method	K0 Can use K1 or K2
Highways Agency Part-turn Method	K0 Can use K1 or K2
Combined Method	K1
Torque Control Method	K2
HRC (TC bolt) Method	K0 with HRD nut otherwise K2



TurnaSure LLC

International Headquarters
340 E. Maple Avenue, Suite 206
Langhorne, PA 19047

Phone: 215-750-1300
Website: www.turnasure.com

Fax: 215-750-6300